

MOBOTIX S15D FlexMount Dual Camera



Two separate rooms

Around corners

Indoors and outdoors

Discreetly In The Background. Doubly Flexible.

With the S15D, up to two 5-megapixel sensor modules are each connected to a concealable camera housing via two-meter long cables. Thanks to its separation of camera housing and sensor modules, the S15D offers a broad range of installation and application scenarios.

- Weatherproof dual installation camera based on the optimized 5MP-MOBOTIX technology platform
- One or two separately connected, discreet miniature sensor modules
- Image sensor and microphone integrated directly into the sensor module
- Double Hemispheric equipment replaces up to eight cameras
- Integrated DVR functionality: Slot for MicroSD card (up to 64 GB)
- Functional expansion via MiniUSB and MxBus connector
- Intelligent movement sensors (MxActivitySensor)
- Can also be used as a Door Station camera or for mobile applications (EN 50155)

MOBOTIX Advantages

Extremely high-sensitive 5-megapixel sensors • All relevant events are automatically saved • Highly secure as motion sensors detect even the smallest movements and reduce the number of false alarms • Cost-effective as fewer cameras are needed thanks to HiRes panorama view • Maintenance-free with no heaters, fans or moving parts • Can be expanded thanks to encrypted two-wire bus (MxBus) • Synchronization via GPS satellite means data available in real time • Weatherproof from -30°C to 60°C (-22°F to 140°F) • No licensing or software fees, free-of-charge updates



Camera Housing (Core)



- Suitable for wall or ceiling mounting
- Robust and maintenance-free with no moving parts
- All available MOBOTIX sensor modules can be connected (L12 to L160)
- Rear metal plate offers optimum heat dissipation

Accessories

SlopeMount 15°



- For mounting at a 15° angle
- Recommended for wall installation with a focus on the center of the room

SurroundMount



- For long, narrow rooms (e.g., hallways, buses, trains)
- Integrates 2 sensor modules (L12, L25, L51)
- For ceiling mounting at a 25° angle

DualMount



- Captures an area with 2 sensor modules (especially day/night)
- Supports all available sensor modules
- For ceiling mounting at a 25° angle

HaloMount/SpeakerMount

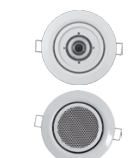

- Mount for sensor modules or standard illuminants (HaloMount)
- Extra speaker (SpeakerMount)
- Built for discreet and simple wall or ceiling mounting, can be tilted by 20°
- Metal, powder-coated or galvanized

MX-Overvoltage-Protection-Box-LSA/-RJ45



- Weatherproof network connector
- Surge protection up to 4,000 volts
- For connecting a network via patch cable or standard network cable

Mobile application



A sensor module mounted to the roof of a car captures the optical condition of a gas pipeline in China as the car passes by.

Technical Data	
Model versions	Sec (all combinations of 5MP day and night sensor modules possible, including LPF)
Lens options	12 to 160 mm format, horizontal angle 180° to 13°
Sensitivity	Color sensor: 0.25 lux at 1/60 s, 0.013 lux at 1 s B/W sensor: 0.05 lux at 1/60 s, 0.0025 lux at 1 s MxLEO – Lowlight Exposure Optimization
Image sensors	1/2.5" CMOS, 5 megapixels, progressive scan
Max. image size (per sensor)	Color: 2048 x 1536 (QXGA), B/W: 2048 x 1536 (QXGA)
Image formats (per sensor)	Freely selectable image format (160 x 120 up to 2048 x 1536); PTZ views: Surround (Quad), fisheye full image, normal, panorama, double panorama, panorama focus (3 views)
Max. frame rate, M-JPEG (live/recording)	VGA: 30 fps, MEGA/HD: 10 fps, QXGA: 4 fps, 6MEGA: 2 fps
Max. video rate MxPEG (live/recording/sound)	VGA: 30 fps, MEGA/HD: 30 fps, QXGA: 20 fps, 6MEGA: 8 fps
Image compression	MxPEG, M-JPEG, JPEG, H.264 (SIP video only)
Internal DVR	MicroSD Slot (recording inside the camera, up to 64 GB; 4-GB card preinstalled)
External storage	Directly on NAS and computer/server without additional recording software
Software (free of charge)	MxEasy video management software, MxControlCenter control center software, MOBOTIX App for iOS devices iOS 5.0 and higher
Image processing	Backlight compensation, automatic white balance, image distortion correction (including panorama image correction), motion detection, MxActivitySensor
Virtual PTZ (vPTZ)	Digital pan/tilt/zoom, continuous 8x zoom, full image recording in the background
Alarm/events	Video motion sensor, MxActivitySensor, external signals, temperature sensor, microphone, shock detector, notification via e-mail, FTP, IP telephony (VoIP, SIP), visual/acoustic alarm, pre- and post-alarm images
Audio (with AudioMount or SpeakerMount)	Integrated microphone (per sensor module), lip-synchronous audio, intercom, sound recording
Interfaces	Ethernet 10/100, IPv4/IPv6, MiniUSB, MxBus; audio (I/O); RS232 via MX-232-IO-Box (accessory)
Video telephony	VoIP/SIP, remote control via key code, event display, intercom function with accessory speaker (e.g., SpeakerMount)
Security	User/group management, HTTPS/SSL, IP address filter, IEEE 802.1x, intrusion detection, digital image signature
Certifications	EMC (EN 55022, CISPR 22, EN 55024, FCC Part15B, CFR 47, AS/NZS 3548), EN 50155, EN 61000-6-1/2
Power supply	Power over Ethernet (PoE in accordance with IEEE802.3af): PoE class variable (2/3) depending on operating mode; power consumption: typ. 4.5 or 5 watts (for 1 or 2 sensor modules)
Operating conditions	IP65 (DIN EN 60529), -30° to +60°C (-22° to +140°F)
Dimensions	Width x height x depth: 11.5 x 13 x 3.3 cm (camera housing/core), Ø x L: 4.3 x 6 cm (sensor module)
Weight	Camera Housing (core) approx. 444 g Sensor module approx. 91 g

Camera Model	S15D-Sec
Lenses, Sensors	
Hemispheric 12 mm (180° x 160°)	L12
Super Wide-Angle 25 mm (82° x 61°)	L25
Wide-Angle 38 mm (55° x 41°)	L38
Wide-Angle 51 mm (40° x 30°)	L51
Tele 76 mm (27° x 20°)	L76
Tele 160 mm (13° x 10°)	L160
Tele 320 mm (7° x 5°)	–
CSVario 28 – 63 mm (28° – 58°)	–
Image sensor with individual exposure zones (B/W sensor modules also available with integrated Long Pass Filter)	Color, B/W (any combination)
Sensor sensitivity in lux at 1/60 s /1 s	Color: 0,25/0,013 B/W: 0,005/0,0025
Image sensor resolution (each color or B/W sensor)	5 MP (2592 x 1944)

Hardware Functions	
Protection class	IP65
Temperature range -30 to +60°C/-22 to +140°F	•
Temporary internal DVR	64 MB
Internal DVR, ex works (max. 64 GB)	4 GB (MicroSD)
Microphone (in sensor modules)/speaker	•/–
Passive infrared sensor (PIR)	–
Integrated temperature sensor	•
Shock detector	•
Power consumption (typical) with one/two sensor module(s)	< 4,5 watts/< 5 watts
Variable PoE class (factory default: 3)	2 or 3

Image Formats, Frame Rates, Image Storage	
Maximum image format (per sensor)	QXGA (2048 x 1536)
Maximum frame rate (MxPEG, max. resolution)	20 fps (QXGA)
CIF images with 4 GB MicroSD DVR	250,000
VGA images with 4 GB MicroSD DVR	125,000
HD images with 4 GB MicroSD DVR	40,000
QXGA images with 4 GB MicroSD DVR	20,000

- available ex works
- not available



Camera Model	S15D-Sec
General Functions	
Digital zoom (continuous) with panning	•
Codecs: Motion-JPEG/MxPEG/H.264 for SIP	•/•/•
Programmable exposure zones	•
Snapshot recording (pre/post-alarm images)	50
Terabyte ring buffer storage (internal/network)	•
Continuous recording with sound (0.2 to 30 fps)	•
Event recording with sound	•
Time and event control/flexible event logic	•/•
Weekly schedules/holidays	•
Web functionality (FTP, email)	•
Playback/QuadView and MultiView	•/•
Bidirectional sound in browser – extra speaker needed	•
Logo generator, animated	•
Master/Slave arming	•
Several scheduled privacy zones	•
Customized voice messages – extra speaker needed	•
VoIP telephony (audio/video, alert) – extra speaker needed	•
Remote alarm notification (network message)	•
Signal inputs/outputs and RS232 via	MX-232-IO-Box
Programming interface (HTTP API)	•
Security Features (HTTPS/S/L, IP-based access control, IEEE 802.1X network authentication)	•
Video Analysis	
Video motion detector	•
MxAnalytics	–
MxActivitySensor	•
Video Management Software	
MxEasy (Windows/Mac OS X)	•
MxControlCenter (Windows)	•
MOBOTIX App (iOS)	•

Delivered Parts S15D Core (Basis Module)

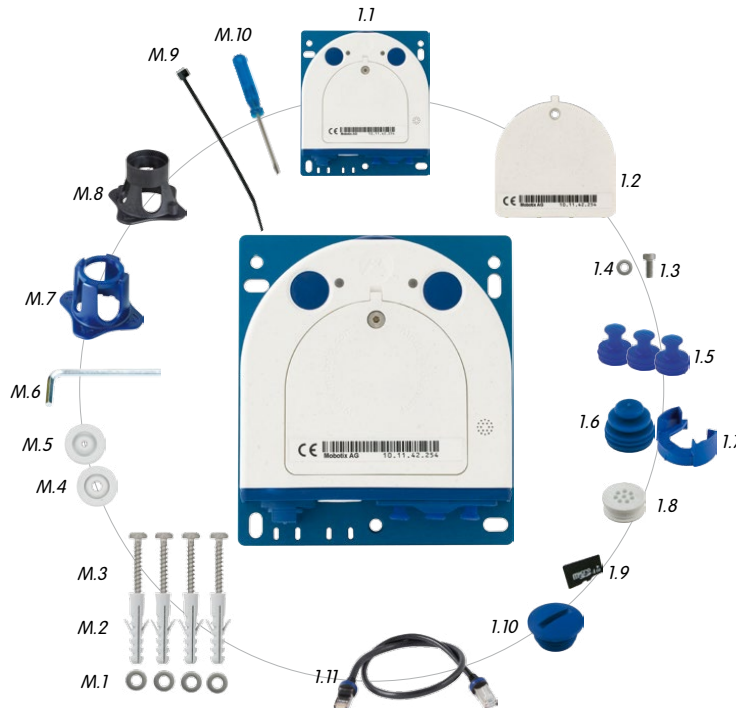

Bottom

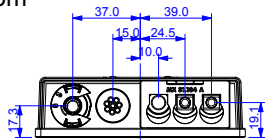

Side

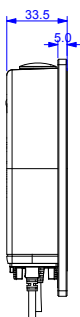

Front

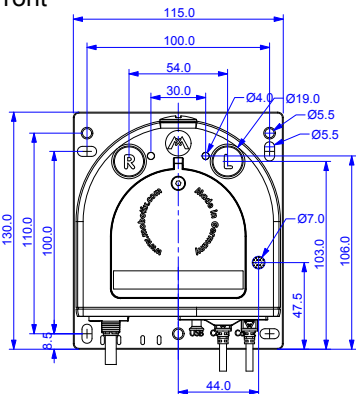

Example with L12 Sensor, ceiling mount.
Each extension gives you 40mm more space.
You can use more than one on every sensor.

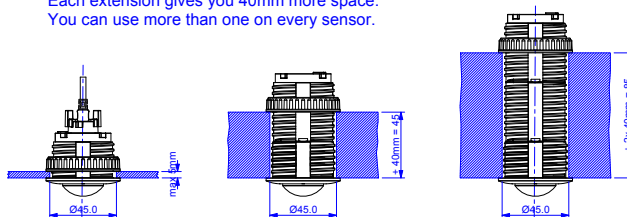

Top

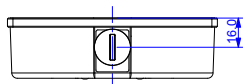

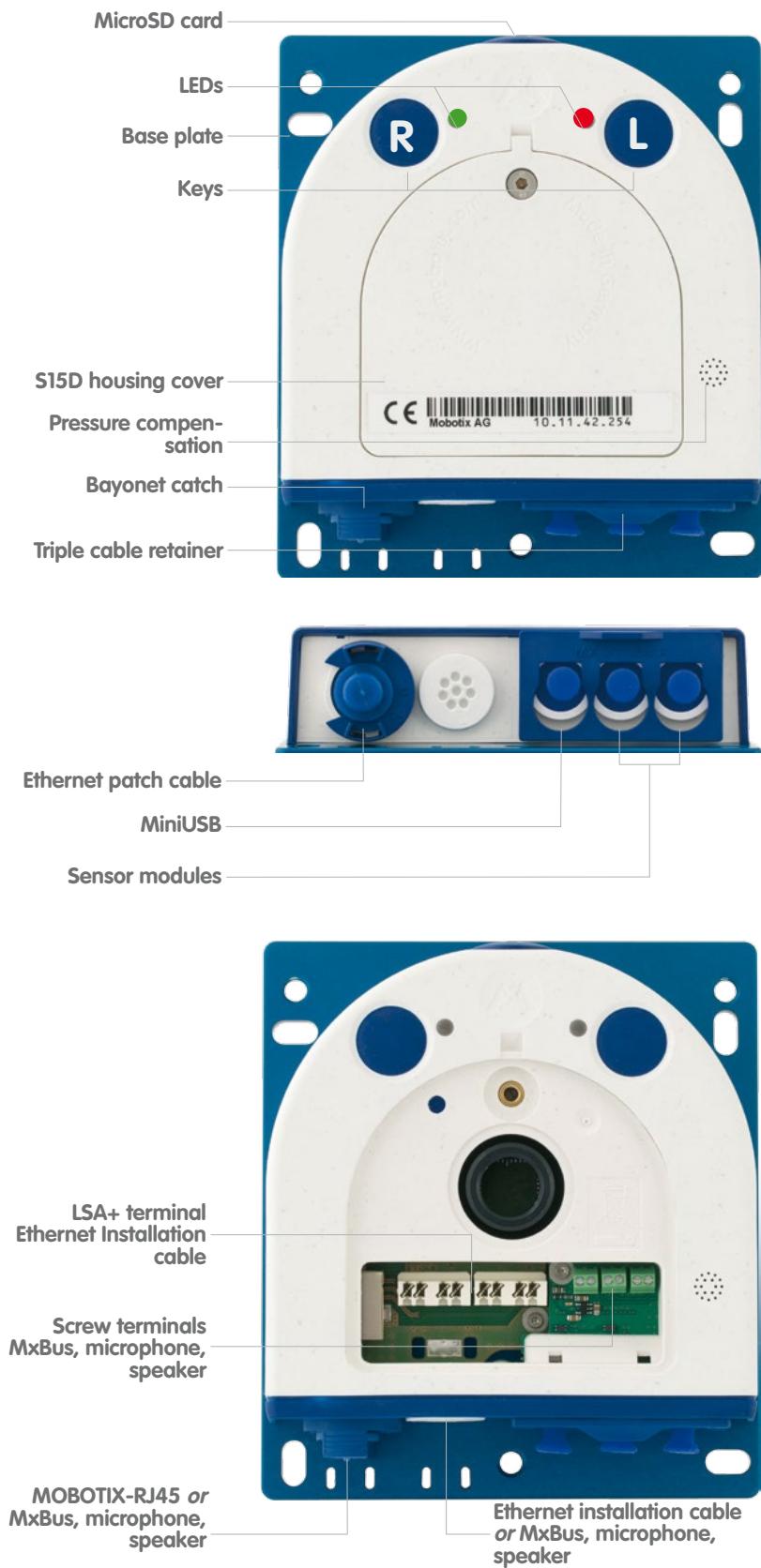

(S15D – Camera housing and connectors, excerpt from the technical documentation)



Modular System For Maximum Flexibility.

The S15D and M15D IP video systems based on the modular MOBOTIX platform concept are equipped with a weatherproof camera core and separately available weatherproof sensor modules. This results in maximum flexibility for a wide range of applications as only a single camera platform is needed: video security applications in commercial, private and public sector environments, as surveillance or weather camera, webcam, indoors or outdoors, day or night.

The 5-megapixel sensor modules of the M15D and the S15D, equipped with microphone and LEDs, are identical and, if required, can be replaced using the special tools shipped with the system. The sensor modules are directly screwed into the camera housing (M15D) or are connected to the discreetly mounted camera housing using connection cables up to two meters in length (S15D). The camera software is preinstalled, so the cameras are ready for use without any additional configuration work required.

Overview: sensor modules for M15D and S15D

The portfolio offers six different focal lengths (lens image angle 13° to 180°) for the M15D and S15D – each as a day or night version. All sensor modules can be freely combined, allowing users to build a camera system ideally suited to any task at hand. Since MOBOTIX cameras are backlight-proof, none of these lenses requires a mechanical auto iris, thus making the camera extremely robust and maintenance-free.

- L12 Hemispheric with 180° image angle (horizontal)
- L25 Super Wide-Angle with 82° image angle (horizontal)
- L38 Wide-Angle with 54° image angle (horizontal)
- L51 Wide-Angle with 39° image angle (horizontal)
- L76 Telephoto with 27° image angle (horizontal)
- L160 Telephoto with 13° image angle (horizontal)